

Design and Implementation of Li-Fi System

Sneha Jadhav, Suchit Shinde, MK Vishnu, Yogita Kore, Poonam Chakraborty

Abstract— Li-Fi (Light Fidelity) is a recent and promising technology which is used for short range, high speed, wireless data transmission. Li-Fi is a part of the VLC (Visible Light Communication) as it is implemented using white LEDs. In this project inexpensive transmitter and receiver is designed using VLC system. The performance evaluation is done under the effect of natural and artificial ambient light noise sources. Also, the effect of transmission distance with respect to optical power, photo sensitivity and correct reception of data will be investigated. The transmission and reception will be done using ASK (Amplitude Shift Keying) modulation and demodulation techniques respectively. The rapid change of intensity of light due modulation cannot be recognized by human eyes. The rate at which the intensity of the LEDs change should be proportional to the sensitivity of the photodetector. Transmission of voice and data signals can also be done using this technology.

Index Terms- Visible Light Communication (VLC), LEDs, Photodiodes, ASK (modulation technique)

1. INTRODUCTION

As the demand for data is increasing exponentially with respect to the available radio spectrum, alternatives are necessary to accommodate the needs of wireless communication systems. This paper illustrates the problems of current wireless communication systems and alternatives to these systems, as well as motivations and possible applications for visible light communications.

Recent advancements in solid state electronic devices such as light emitting diode (LED) has triggered. The possibility of illumination along with communication which is popularly known as Visible Light Communication system(VLC).

The conventional fluorescent lamps in offices and homes environments will be replaced by white LEDs in future. This is because the white LEDs have advantages like longer life time, low energy consumption and less health hazards. VLC, due to its properties, can be implemented even in RF prohibited areas like hospitals and airplanes. Some of the applications of VLC are undersea communication, road to vehicle communication, monitoring patient in hospitals, in flights for communication or entertainment and location based communications.

In this project, transmitter and receiver circuit is designed for the proposed VLC system with respect to the influence of external light noise source such as fluorescent lamp inside the room and indirect sunlight coming from the window placed near to the VLC system.

VLC is standardized by the Institute of Electrical and Electronics Engineers (IEEE).

2. LITERATURE SURVEY

2.1 Visible Light Communication Concept

Visible Light Communication (VLC) is an optical communication that is wireless. It carries information by modulating light in the visible spectrum. Its operating Range is from 400nm– 700nm. The communication signal (i.e. the modulating signal) is encoded on the illuminating light. Motivation to use the illuminating light is to save energy. This technology is considered “green and safe” with comparison to radio frequency (RF) technology. One of the major advantage of VLC is that we can use the infrastructure around us without making any changes to it. When we are talking about VLC we are considering an illuminating source (LEDs in this paper) which can

illuminate as well as send information using the same illumination. So, in our terms:

$$\text{VLC} = \text{Illumination} + \text{Communication}$$

Imagine a flashlight which is used to send a Morse code signal. When you are operating manually this will send data using the light. This is because it is flashing off and on and it would not be a useful illumination source, so this is not really VLC by our definition. Now imagine that the flashlight is switched on and off extremely fast via a computer. Now we are not able to receive the data. Flash light appears to emit a constant stream of photons i.e. light. So we have achieved illumination and communication which does fits our definition of VLC. We would also need a receiver that will receive the information and it is not too difficult to achieve.

2.2 ASK (Amplitude Shift Keying)

Amplitude-shift keying (ASK) is a form of amplitude modulation. It shows that the digital data is represented as variations in the amplitude of a carrier wave. Any modulated signal has a high frequency carrier. The binary signal when ASK modulated, gives a zero value for low input while it gives the carrier output for high input.

3. SYSTEM MODEL

3.1 Sections of the System

- Amplitude- Shift Keying (ASK) Modulator
- Amplifier
- White LEDs
- Photodiode
- Envelope Detector
- Filter

3.2 Basic block diagram

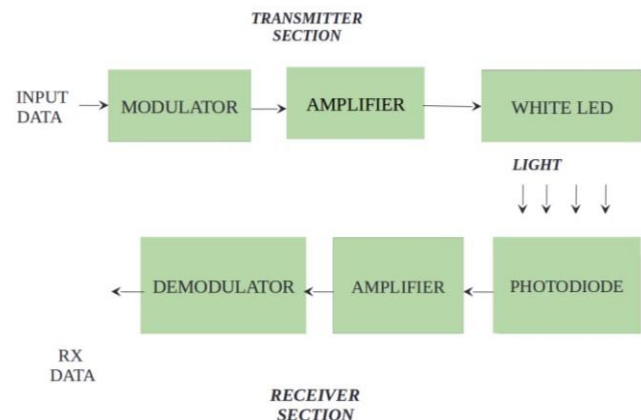

Fig. 1 Block Diagram

4. HARDWARE DESCRIPTION

4.1 Amplitude- Shift Keying (ASK) Modulator Amplitude-Shift Keying (ASK) is the digital modulation technique in which low frequency modulating signal is superimposed on high frequency carrier signal for long distance transmission. For ASK signal generation IC 4015B is being used in the project. It is a multiplexer IC. The pin diagram is shown below: -

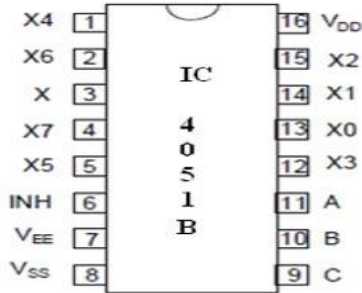

Fig. 2 Pin Configuration

PIN NO.	SYMBOL	NAME AND FUNCTION
3	X	Common Input/Output
6	INH	Inhibit Inputs
7	V _{EE}	Supply Voltage
8	V _{SS}	Ground
9,10,11	A,B,C	Binary Control Inputs
1,2,4,5,12,13,14,15	X0-X7	Independent Input/Outputs
16	V _{DD}	Positive Supply Voltage

Fig.3 Pin Description

The functions of the pins are shown in the table above.

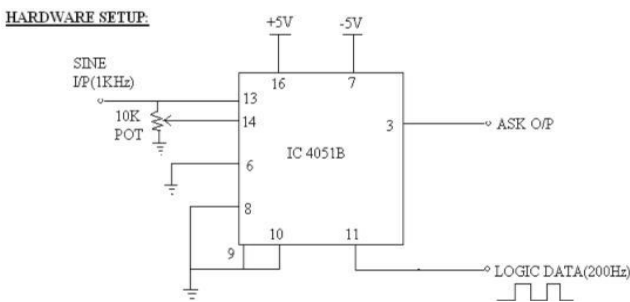

Fig 4. ASK Modulator

The hardware setup is shown in the figure above. The sine wave (carrier signal) is applied at pin no. 14. The modulating signal is given at pin no. 11. The modulating signal is of 200Hz. The carrier frequency is set to 2KHz. The potentiometer that has been used is of 47Kohms. The ASK output is observed at pin no. 3. The output of the modulator is amplified so that the voltage produced is suitable to drive the LEDs. The amplifier in the modulator section is a noninverting amplifier.

IC 4051B is used for multiplexing as a carrier and a modulating signal is sent together. ASK generation is possible by using IC 555. But ASK generation using IC 555 needs two ICs. Whereas by using only one IC 4051B we can generate ASK signal.

4.2 Voltage Amplifier

At the output of ASK Modulator section the value of voltage which is required to drive LEDs is very low. So, to drive LEDs, we

required to amplify the voltage. Voltage amplifier is designed using OP-AMP IC 741 in the non-inverting configuration.

4.3 LEDs

This system would require some special LEDs as the transmission is done in meters and kilometers. The normal LEDs that are used in the lab circuits have a very less luminous intensity. The luminous intensity is a measure of how bright the LED can get. The standard unit for measuring light intensity is candela (cd).



Fig 5. Super bright white LED

So, the LED that is being used in this system is the Super bright white LED. This LED provides an intensity of 16,000-20,000 millicandela (mcd). It has a 30-degree viewing angle.

4.4 Photodiode

With respect to the LED that is used the photodiode selected is SFH 231. The semiconductor material used is germanium. This photodiode is suitable for applications from 600nm to 1800nm. It has short switching time typically 9ns.



Fig 6. SFH 231

4.5 Envelope Detector and Filter

An envelope detector is an electronic circuit that takes a high-frequency signal as input and provides an output which is the envelope of the original signal. This system is using this circuit in the demodulator section.

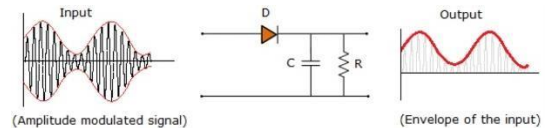

Fig 7. Envelope Detector Circuit

The ASK modulated output is applied to the detector circuit. The input signal is rectified by the diode D in the detector circuit. The combination of the capacitor C and resistor R acts as low-pass filter. The capacitor helps in filtering out the RF carrier waves present in the input signal i.e. the ASK modulated output. Thus, the capacitor helps in giving an envelope of input as output.

5. LI-FI vs WI-FI

Of all the wireless technologies that are used the latest LiFi technology is the best one. Wi-Fi is widely used everywhere and is the most talked

about technology in present era. So, the below table show the basic difference between Li-Fi and Wi-Fi.

Sr. no.	Li-Fi	Wi-Fi
1.	Li-Fi transmits data using light with the help of LED bulbs.	Wi-Fi transmits data using radio waves with the help of Wi-Fi router.
2.	Do not have any interference issues like radio frequency waves.	Will have interference issues from nearby access points(routers)
3.	In Li-Fi, light is blocked by the walls and hence will provide more secure data transfer.	In Wi-Fi, RF signal cannot be blocked by the walls and hence need to employ techniques to achieve secure data transfer.
4.	Data transfer speed about 224 Gbps.	Data transfer speed about 150 Mbps
5.	Frequency of operation is 10 thousand times frequency spectrum of the radio.	Frequency of operation is 2.4GHz, 4.9GHz and 5GHz.
6.	Applications: Used in airlines, undersea explorations, operation theaters in the hospitals, office and home premises for data transfer and Internet browsing.	Applications: Used for Internet browsing with the help of Wi-Fi kiosks or WiFi hot-spots

6. RESULT ANALYSIS

The following observations and calculations were made: -

6.1 Modulator section

- Output at modulator=0.47V
- Modulation frequency= 2KHz
- Logic data frequency= 200Hz
- Calculations of voltage to drive LEDs=

1. Gain =11
2. Non-Inverting amplifier= $1+(Rf/R1)$
3. Input to non-inverting amplifier=0.47V (ASK Output)
4. $R1=1k, Rf=10k$
5. Input to LEDs from ASK= 2.53V

6.2 Demodulator section

- Gain of amplifier=22
- First Low pass filter (1st order) =

1. $F_c=1.5 \text{ KHz}$
2. $C=10 \text{ nF}$ (Assume)
3. $R=1/(2*\pi*F_c*C)=10.61 \text{ KOhms}$

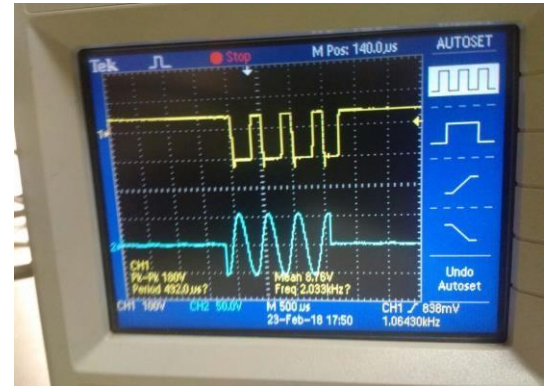

Fig 8. Demodulator output

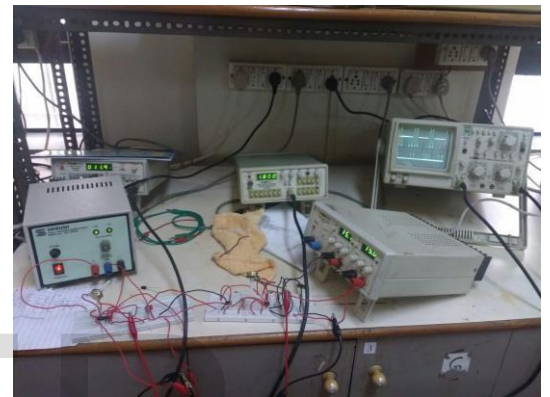

Fig 9. Entire setup

REFERENCES

- [1] Shlomi Arnon, "Visible Light Communication" Ben-Gurion University the Negev, Israel Cambridge University Press.
- [2] Shubham Chatterjee & Shalabh Agarwal, "Scope and Challenges in Light Fidelity(LiFi) Technology in Wireless Data Communication" International Journal of Innovative Research in Advanced Engineering (IJIRAE) , ISSN: 2349-2163, Issue 6, Volume 2 (June 2015).
- [3] Manas Ranjan Mallick, "A Comparative Study of Wireless Protocols With Li-Fi Technology: A Survey", International Journal of Advanced Computational Engineering and Networking, ISSN: 23202106, Volume-4, Issue-6, June-2016.
- [4] Anurag Sarkar, Dr. Asoke Nath, Prof. Shalabh Agarwal, "Li-Fi Technology: Data Transmission through Visible Light", International Journal of Advance Research in Computer Science and Management Studies, ISSN: 2321-7782 (Online)Volume 3, Issue 6, June 2015.
- [5] www.YouTube.com – TED Talk by Harald Hass on Li-Fi. [6] K. Sindhubala and B. Vijayalakshmi, "Design and implementation of visible light communication system in indoor environment", ARPN Journal of Engineering and Applied Sciences, VOL. 10, NO. 7, APRIL 2015.
- [7] Casey Barney, Alexander Dich and Dennis Koufos, "Visible light Communication Systems", Worcester Polytechnic Institute, project report- 2014.

[8] Rahul R. Sharma, Raunak, Akshay Sanganal, “*Li-Fi Technology Transmission of data through light*”, Int.J.Computer Technology & Applications, ISSN:22296093,Vol 5 (1),150-154.

[9]<http://www.rfwireless-world.com/Terminology/Advantages-and-Disadvantages-of-LiFi.html>

[10] <https://purelifi.com/technology/>

IJSER